

Besam BDS

- Balance Door Systems



The Balance Door System is very effective in windy conditions, combining the benefits of a swing and sliding door system. A perfect solution for narrow passages or in corridors.



Perfect for narrow passage ways

The Besam automatic balance door has incorporated the advantages of both conventional swing doors and normal sliding doors. Constraints of safety and reliability with many door installations mean that the balance door will often be the only natural solution. Wherever there is minimal space for a door leaf that swings open, there is no other alternative than the balance door.

Perfectly balanced

The balance door is less vulnerable to severe wind loads, cross-draughts as well as pressure differences. The door is always perfectly balanced despite the lateral pressure and this ensures that it is easily opened even during severe conditions.

Standard equipment

Jamb with outer dimensions 45x114mm made from clear anodized aluminium

Door leaves, with 6 or 8mm laminated glass, made from clear anodized aluminium, thickness 48mm

Finger protection rubber extrusion

SW100 Swing Door Operator

Accessories and Options

Other paint finishes optional

The Besam range of activation units

Programme selectors

Insulated glass, thickness 22 or 40mm

Mechanical hook bolt lock on the door leaf

Electromechanical lock

Espagnolette lock

Flush bolt lock

Midrail (70 or 150mm)

Extended top rail 175mm

Extended bottom rail 201mm

Built-in safety, reliability and economy

The balance door is completely suspended in the frame without guide grooves in the floor. This is a method which is functional and safe and at the same time economical in both installation and maintenance. Finger guards between the door leaf and the jamb reduce the risk of accidents.

The BDS Door is fully approved towards the safety regulations for Europe EN16005.

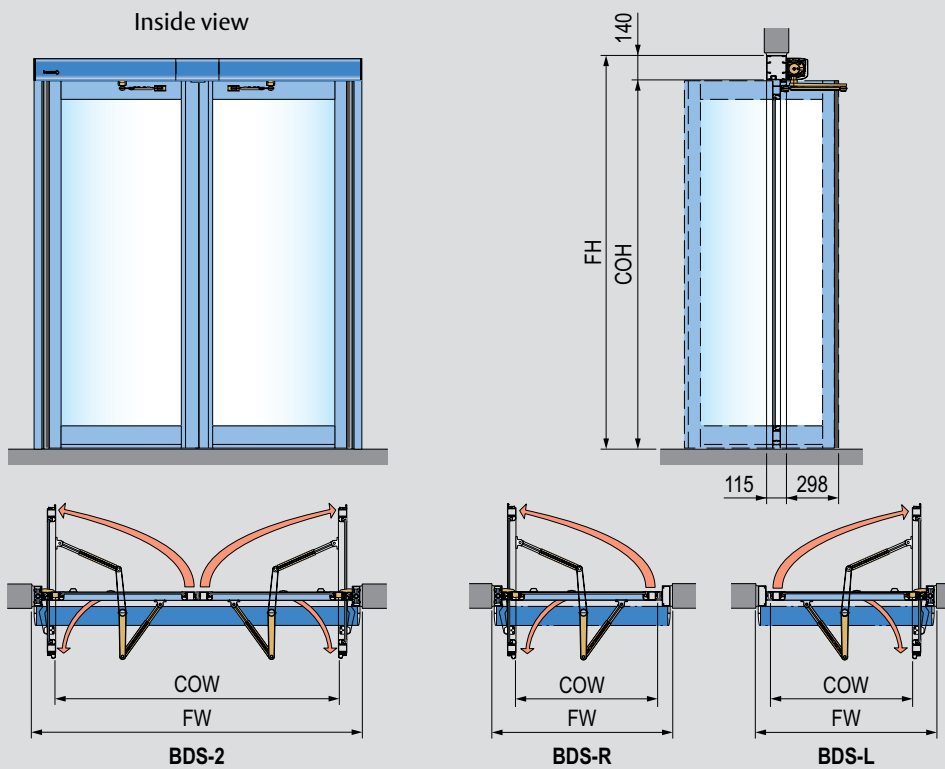

Design

The Besam balance door system is always tailor-made to suit differing customer requirements, and has a stable and functional construction. The system is pre-fabricated to ensure that all parts are a perfect fit when installed on the site. The door system is delivered complete with jamb, glazed door(s) and operator(s) with arm system(s) PUSH.

Small but strong

The BDS-system will be equipped with the highly reputed Besam SW100 swing door operators. The operators have been designed to cope with tough conditions. Strong gusts of wind or intensive traffic flows pose no problems.

Sizes

Type	FW min	FW max	FH min	FH max
BDS-L	852	1190	2090	2740
BDS-R	852	1190	2090	2740
BDS-2	1482	2240	2090	2740

Clear opening width (COW) =
FW-190 (BDS-L/R) and FW-250 (BDS-2)

All dimensions in millimetres

Models

BDS-L: Left hand door; a complete unit consisting of jamb/header assembly and door leaf

BDS-R: As BDS-L, but right hand door

BDS-2: Double doors; a complete unit consisting of jamb/header assembly and door leaves

Technical specifications

See operator product sheet



This equipment should be installed, regularly inspected, maintained and serviced by trained and authorized personnel. Preventive maintenance plans are highly recommended for a proper and safe operation. Talk to your ASSA ABLOY Entrance Systems representative to learn more about our service offering!

ASSA ABLOY Entrance Systems

Box 669, SE-261 25 Landskrona
Sweden
export.se.besam@assaabloy.com
Phone: +46 10 47 47 000
Fax: +46 418 212 50
www.besam.com

www.assaabloyentrance.com

ASSA ABLOY

The global leader in
door opening solutions