



# SlimStile EV

## Tripod Turnstile for Internal or External Installation

Tripod Turnstiles are compact and cost-effective entrance solutions designed for smooth and silent operation, less wear and tear and reduced power consumption, suitable for areas where there is a large flow of people.

SlimStile EV offers a well-designed, two-legged casework made of stainless steel, ideal for sites where large flows of people and robustness are issues. Available a 316 grade stainless steel version and an outdoor version IP44, 316 stainless steel. A Double version is also available. On receiving a signal from the access control system, or push button, it allows the passage of one person at a time.

The status is shown on the led-way mode indicators, in entry and exit side.

In case of emergency the hub freely rotates to allow an easier exit. You can also choose the drop arm option which automatically drops the horizontal arm to allow free passage. Passage in both directions is electronically controlled. Available in Normally Closed (N/C) configuration to lock the mechanism until a valid authorisation signal is received, or available in Normally Open (N/O) configuration to lock the mechanism in the event of attempted unauthorised entry. The N/O configuration allows also reduced power consumption and increases the life of the mechanism and passage through put speed.



# SlimStile EV

## Technical Specifications

### Drive

Hand-operated

### Materials

Casework:	304 grade grained stainless steel
Casework lid:	304 grade grained stainless steel
Tripod hub:	Cast aluminum with painted grey finish
Tripod arms:	38mm dia. 480mm 304 polished stainless steel

### Mechanism

Electro-mechanical head mechanism:

- Positive locking action for one passage at a time
- Self-centering mechanism to ensure complete rotation into the home position
- Hydraulic damper to ensure smooth operation
- Anti-backup device to prevent reverse rotation once the mechanism has moved 60° from home

### Power Failure / Fire Alarm

Either one or both directions can be fail-safe (standard), i.e. rotates freely, or fail lock, i.e. locks in the home position.

Fire alarm – emergency input. Input facility available for free voltage contact to effect fail state.

Mechanism fail state will be the same as power failure choice.

Drop arm option: the horizontal arm drops to create a clear passage for evacuation.

### Interface

LL2001Lite microprocessor control logic:

- One input for opening/locking in each direction
- Two protected outputs controlling opening/locking
- Four protected outputs piloting way mode indicators
- Two protected outputs counting passage in ether directions
- Two 0V output relays indicating availability of use or counting passage in either direction
- Two open collector NPN outputs to count passage or to indicate availability of use in either direction or activate the optional drop arm feature
- Serial Port – RS485

### Power Supply / Power Rating

230 Vac 50Hz or 115 Vac 60Hz. Power Rating 50VA (stand by 5VA if Normally Open).

### Operating Temperature / IP rating / MCBF

0 to +45°C (RH 95% not condensing) / IP 20 (44 if outdoor version) / 1.5M cycles (2.5M if Normally Open)

### Flow Rates (approximate figures)

Insertion Type Reader: 20 passages per minute

Swipe Type Reader: 30 passages per minute

### Models or Versions

- Single
- Double
- Outdoor – (single only)  
IP44, 316 grade stainless steel

### Options

- Card reader mounting
- Remote control MP2000
- Push button control
- Pictograms
- LCD counter
- Drop arm
- 316 stainless steel (single only)

### Application Areas

- Government
- Retail
- Finance
- Telecommunications
- IT
- Banking
- Publishing
- Leisure
- Petrochemical
- Education

# SlimStile EV

## Site Preparation

Product delivered fully assembled and may require lifting equipment. Approx. weight: 50 kg . Double version 95 kg.  
(please for installation details refer to the proper Installation Layout drawings)

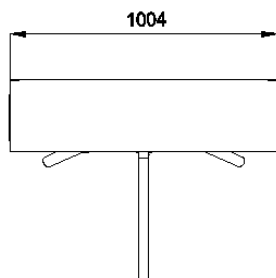
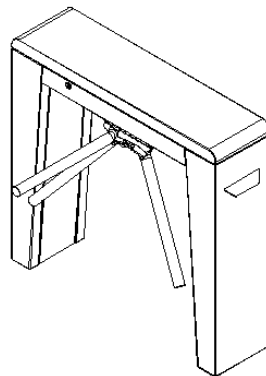
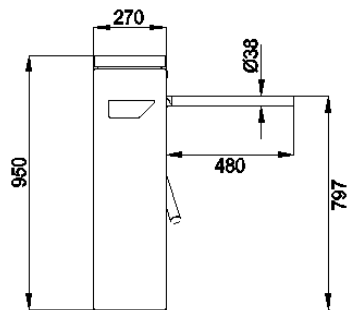

Single cabinet version

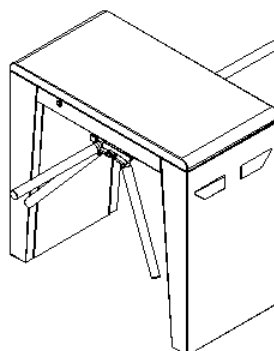
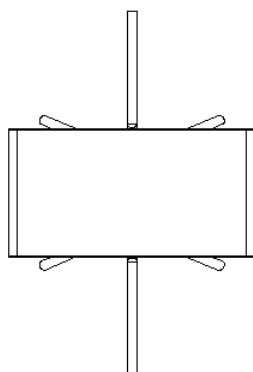
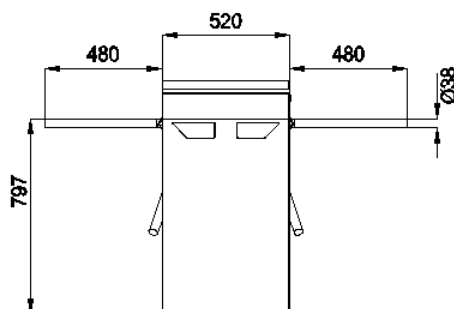
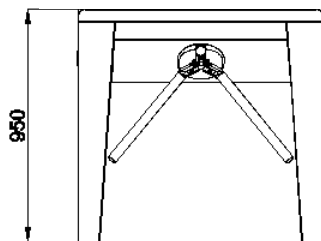

Concrete Base to specification at least fck (cube) 300N/mm<sup>2</sup> of resistance. Base to be flat and level to +/- 5mm over footprint area. Dimensions to be > 1200 x 500 x 150 deep min (1200 x 650 x 150 mm for Double version)

# SlimStile EV

## Important

- Any horizontal pipe or conduit running below the Tripod Turnstile must be at least 140mm below FFL.
- Metal conduit for cables should be raised at least 50mm from foundation
- It is the customer's responsibility to ensure the structural integrity and strength of the installation location.
- The dimensions given in this Product Data Sheet are for information only. In order to prepare the installation site, please refer to your usual Gunnebo Customer Service contact.

For further information please contact:

### Competence Centre Entrance Control

c/o Gunnebo Entrance Control Ltd

Bellbrook Business Park, Uckfield, East Sussex, TN22 1QQ

United Kingdom

Tel +44 1825 761 022

Fax +44 1825 763 835

E-mail [info.entrancecontrol@gunnebo.com](mailto:info.entrancecontrol@gunnebo.com)

Web [www.gunnebo.com/entrancecontrol](http://www.gunnebo.com/entrancecontrol)



Note: In pursuit of its policy of continuous refinement and improvement, Competence Centre Entrance Control reserves the right to modify design and details.

A COMPANY WITHIN THE GUNNEBO GROUP

Head Office Sweden

Gunnebo AB, Box 5181, SE-402 26 Goteborg, SWEDEN. Tel +46-31 83 68 00, Fax +46-31 83 68 10

[www.gunnebo.com](http://www.gunnebo.com)

**GUNNEBO**  
For a safer world®